

KENDRION



INTORQ

POWERED BY KENDRION

KENDRION SOLUTIONS

INTORQ BFK551

Spring-applied brake with intelligent design
in its most compact form

PRECISION. SAFETY. MOTION.

Our brakes – perfect for your safe application

KENDRION Industrial Brakes – stands for smart innovation and excellent service, which we consistently apply for the benefit of our customers:

Strong know-how

Our specialists develop the leading-edge permanent magnet and spring-applied brakes. With INTORQ as a new member of KENDRION, we have once again consistently expanded our range of spring-applied brakes and clutches for you. This way, we can find the right solution for any of your requirements.



Complete product portfolio

Electromagnetic brakes and clutches as well as perfectly matched accessories: with us you will find an exceptionally large selection of quickly available off-the-shelf products that can be put together in a modular system and the best expertise for customer-specific solutions.

Dynamic innovative power

More than 50 specialists working in agile teams in our research and development worldwide are creating convincing product solutions for tomorrow.

Excellent market knowledge

We are very familiar with our focus markets – thanks to extensive experience and research, but also thanks to long-term customer relationships built on partnership and eye-to-eye cooperation.

International power

Committed and competent employees, production sites in Germany, United States, India and China as well as a large number of certified sales partners all over the world make us a strong partner for you!

The INTORQ BFK551

On the point

- Fail-safe spring applied brake
- Flat, space saving design
- Dynamic or holding brake with emergency stop function
- Best suited for small DC motors
- Compact, preset solution with integrated fastening screws
- UL certified and available worldwide



Suitable for the use of:





The INTORQ BFK551 – the better choice

With the new INTORQ BFK551, we are taking our product portfolio of small, compact spring-applied brakes to a new level. The innovative design of the INTORQ BFK551 offers the market an optimized mounting concept.

With its space-saving size the INTORQ BFK551 can be easily integrated into new and existing drive solutions. The special housing design significantly increases the friction radius, which makes the INTORQ BFK551 the more powerful solution compared with competitors' products.

The compact unit of the brake, with a fixed air gap and integrated mounting screws, allows for a simple and cost-effective installation. Moreover, there are no maintenance costs.

Optimized subassembly prefabrication and final assembly at the customer's site guarantee sustainable future-proof quality. Our international network of production plants and service facilities ensures excellent global reach and availability – wherever you are in the world.



Quickly available brake with cost-saving mounting concept



Technical highlights

- Compact, pre-assembled brakes
- Maintenance free
- Quick and easy installation
- Options: Special fastening screws, various mounting directions, all standard voltage options and hub bores

Technical data



Design types	Can be mounted on the housing or flange side
Standard rated voltages	24 V, 103 V, 180 V, 205 V
Protection class	IP00
Thermal class	F (155°C)
Ambient temperature	-20 to 40°C
Min. holding torques	0,24 to 4 Nm
Duty time	100% ED
Nominal backlash	1°
Options	Rated voltage, hub bore, Mounting direction, hand release (BG03-05)
Note	Please read the general information on data sheets and the corresponding operating instructions. Design subject to change without notice.

Brake size	Rated torques for operating brakes @100 [min ⁻¹]	Rated torques for holding brakes @100 [min ⁻¹]	Maximum speed n _{max} [min ⁻¹]	Shifting work for single shift W _{max} [J]	Number of emergency stops Z _{ges} [-]	Friction work until maintenance for service brakes with WR lining Q _{BW} [MJ]
01	–	0.24	5000	200	500	–
02	–	0.5	5000	400	500	–
03	0.5	1	5000	800	500	7
04	1	2	5000	1200	500	9
05	2	4	5000	1800	500	11



Not found
the right brake?
Talk to us!

Dimensions

Brake size	Hub bore d H7 [mm]	Fastening screws d ₁ [mm]	Screw hole circle d ₂ [mm]	Inner diameter d ₃ [mm]	Outer diameter d ₄ [mm]	Flange inner diameter d ₅ [mm]	Length l [mm]	Length l ₂ +/-0,9 [mm]	Length l ₃ [mm]	Height h [mm]	Height h ₂ [mm]	Height h ₃ [mm]	a [mm]	b [mm]	c [mm]
01	5/6	3xM2.5	32	13.5	37	16.8	10	3.6	3.4	31.1	1	19...22	-	-	-
02	6/7/8	3xM3	40	16	47	19.8	10	5	4.8	31.2	1	19...21	-	-	-
03	6/7/8/9/10	3xM3	48	16	56	28.8	15	4.8	4.3	31.8	1	16...22	58	88	15
04	6/7/8/9/10	3xM3	58	18	65	33.8	15	4.8	4.3	31.8	1	16...21	68	103	15
05	6/7/8/9/10/12/15	3xM4	66	24	75	38.8	15	5.4	6.6	34.8	1	19...22	80	118	20

With hand release

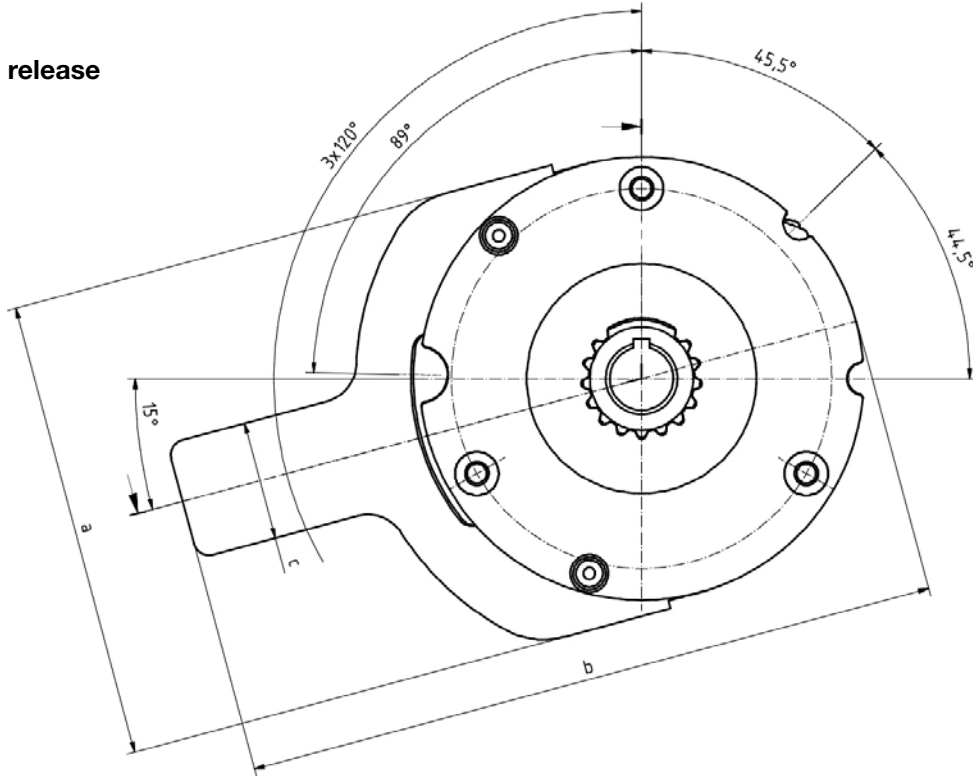

Flange mounted with hand release

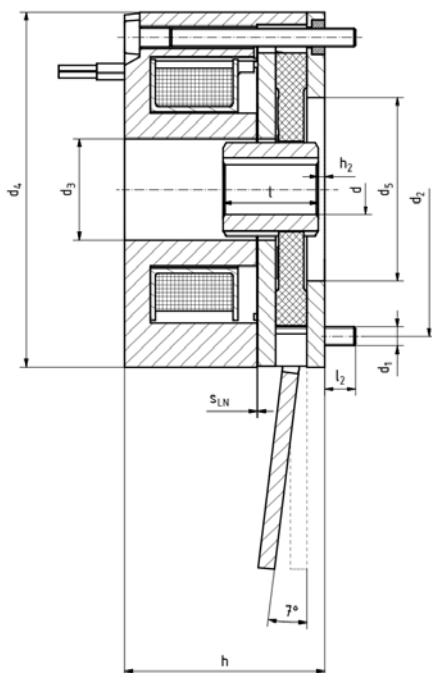



For an overview of the many standard options available, we offer you a choice of combinations. All features are available at short notice and have been extensively tested.

Design

- Mounting direction** Housing-mounted
 Flange-mounted
- Version** Operating brake minimum rated torque [from size 03]
 Holding brake maximum rated torque
- Brake size** 01 02 03 04 05
- Voltage** 24 V 103 V (from size 03) 180 V (size 05) 205 V (from size 02)
Other voltages between 12 V and 250 V possible.
- Fastening screws** Pre-mounted for all designs according to the mounting direction

Options

- Hub** For bore diameter, see dimensions
- Hand release** Mounted (from size 03)



You will find the right design for your application in our product finder!







INTORA
POWERED BY KENDRION

KENDRION

Customized solutions – tailored exactly to your needs

Automation solutions have become an indispensable part of industry and everyday life. In this context, it is often the brakes that ensure safety: They hold loads and brake reliably in an emergency.

Just as automation continues to evolve, brakes must also face higher demands – forward-looking products are in demand. At the same time, quality and safety must be unconditionally guaranteed. This is a challenge that Kendrion Industrial Brakes meets with passion and care.



When it comes to developing customer-specific solutions, we have three aces up our sleeves:

- With our **new agile organization**, we respond much faster to customer requests.
- Our **modularly developed products** enable new configurations without complete redevelopment.
- The **global structure of our organization** bundles competencies and ensures valuable knowledge transfer.

This makes us a competent and reliable partner for our customers – starting with industry-savvy consulting, through product development with practical experience, to uncompromising quality assurance.



We will find the
solution that suits
you best!



KENDRION

Kendrion INTORQ GmbH

Wülmser Weg 5
31855 Aerzen
Germany

T +49 5154 70534-222
sales-aerzen-ib@kendrion.com

INTORQ US INC.

106 Northpoint Parkway
Acworth, GA30102
USA

T +1 678 236 0555
F +1 678 309 1157
info-atlanta-ib@kendrion.com

Kendrion (China) Co., Ltd.

No.10 Huipu Road,
Suzhou Industrial Park
Suzhou City
Jiangsu Province
China

T +86 21 20363 810
F +86 21 20363 805
sales-china@kendrion.com

INTORQ India Pvt. Ltd.

Plot No E-2/7
Chakan Industrial Area, Phase 3
Kharabwadi, Taluka – Khed
Pune, 410501, Maharashtra
India

T +91 21 3562 5500
info-pune-ib@kendrion.com

www.kendrion.com

© KENDRION 12.02.2023

PRECISION. SAFETY. MOTION.